MITSUBISHI SEWING MACHINE PARTS CATALOG

Model.....CU-865

INDEX

1.主 体 関 係.....	Arm bed & its accessories	L65-1
2.上糸調節器関係.....	Thread tension regulator cpl.....	L65-3
3.押 え 関 係.....	Presser foot mechanism.....	L65-5
4.上軸押え上げ関係.....	Arm shaft & knee lifter lifting lever mechanism.....	L65-7
5.針棒揺動関係.....	Needle bar rock shaft mechanism	L65-9
6.天秤 針棒支え関係.....	Needle bar rock frame & thread take-up mechanism	L65-11
7.送り調節器関係.....	Stitch length regulator mechanism	L65-13
8.縦軸・下軸関係.....	Vertical shaft & rotating hook shaft mechanism	L65-15
9.返し縫い関係.....	Reverse sewing mechanism	L65-17
10.送 り 関 係.....	Feed rock shaft mechanism	L65-21
11.給 油 関 係.....	Lubrication mechanism	L65-23



MITSUBISHI ELECTRIC CORPORATION

197711

CU-865形 機構図 TOTAL ASSY,

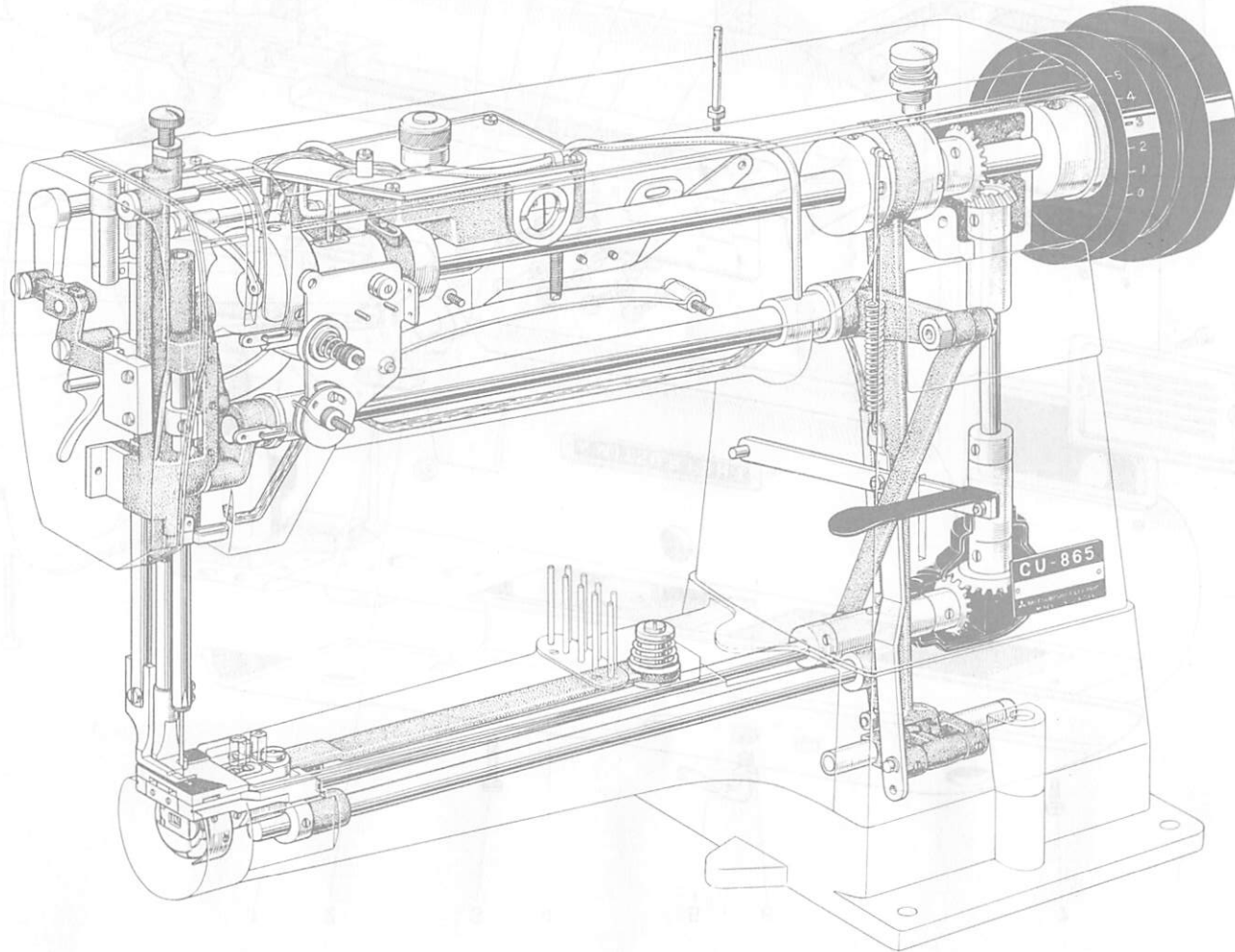

CU-865形 手縫機 針車 針車 針車 針車 針車 針車 針車 針車 針車 針車

CU-865形 主体関係 ARM BED & ITS ACCESSORIES

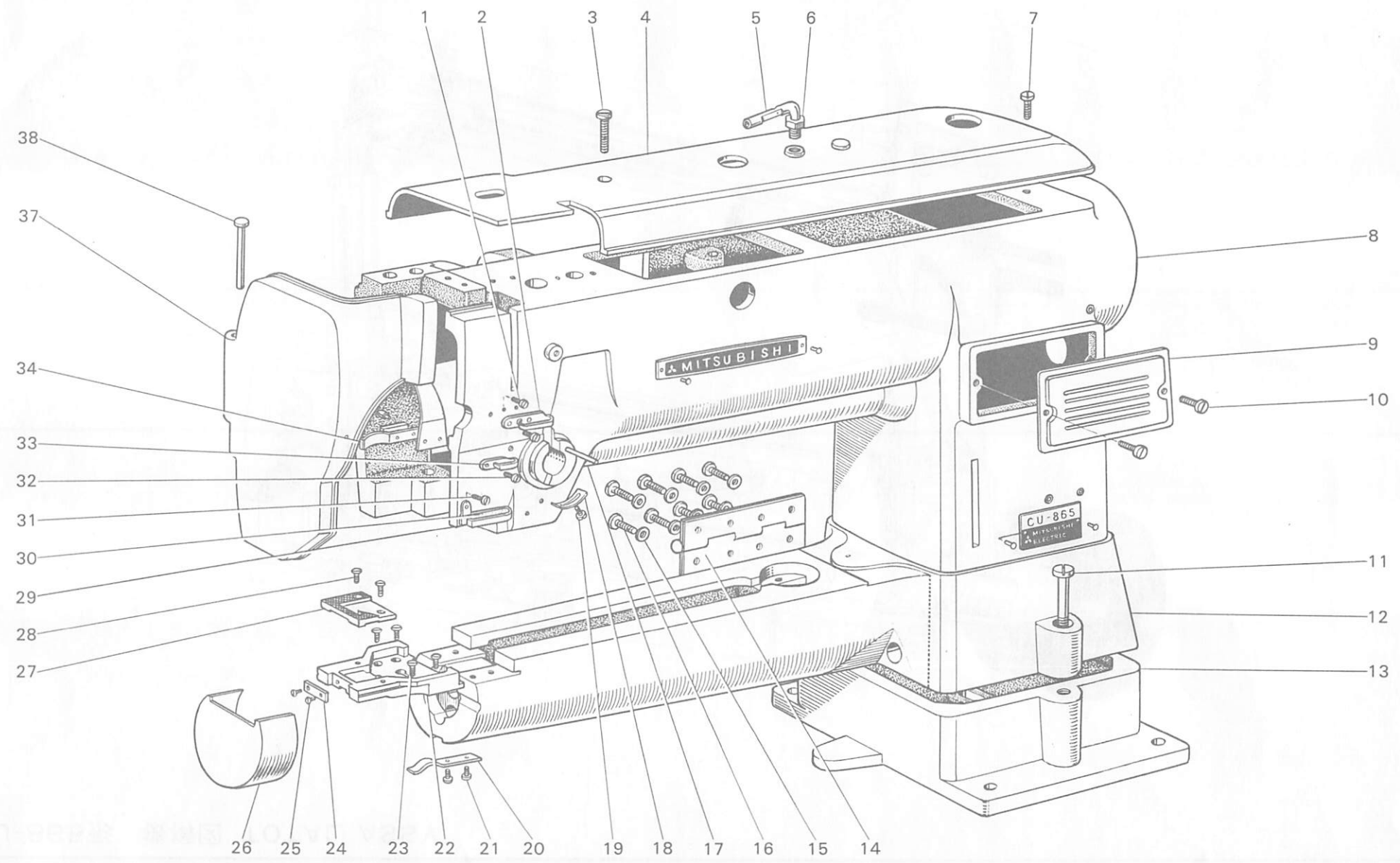

<CU-865形> 主体関係 ARM BED & ITS ACCESSORIES

Fig. No.	サービス部品コード Part No.	資材コード Code No.	部 品 名	Name of Part	個 / 台 Amt. req					備 考 Remarks
1	M9 0904 011	W500147	丸 皿 ネ ジ 9/64(40)×6.5	Screw (for Fig. 2) 3/16(28)×11						
2	MN 10A0 181	W445857	糸カケ(アーム上)	Arm thread guide						
3	M9 0918 002	W500262	平 ネ ジ 9/64(40)×23	Screw (for Fig. 4) 9/64(40)×23						
4	ML 65B0 600	W220651	ト ッ プ カ バ ー	Top cover						
5	MN 10A2 181	W445861	糸カケ(トップカバー)	Top cover thread guide						
6	M9 1202 045	W500001	ナ ッ ト 3/16(28)×4	Nut 3/16(28)						
7	M9 0915 002	W500261	平 ネ ジ 9/64(40)×14	Screw (for Fig. 4) 9/64(40)×14						
8		W111533	ア ー ム	Arm						
9	MN 10A0 800	W461026	前 ブ タ	Side cover						
10	M9 1101 004	W466810	ブ ラ マ イ ネ ジ 11/64(40)×8	Screw (for Fig. 9) 11/64(40)×8						
11	M9 2071 003	W501920	丸 平 ネ ジ 5/16(18)×18	Screw (for Fig. 12) 5/16(18)×31						
12		W111535	ベ ッ ト	Bed						
13	ML 65B1 603	W220650	ベ ッ ト 土 台	Bed						
14	ML 65B0 560	W464450	平 形 蝶 番	Hinge						
15	M9 0302 053	W462953	バ ネ 座 金 3.5	Washer (for Fig. 14)						
16	M9 1510 002	W500676	平 ネ ジ 15/64(28)×12	Screw 15/64(28)×12						
17	M9 0402 060	W462904	糸ユルメピン(大) 4φ×57	Tension releasing pin						
18	MN 10A0 477	W445942	糸取りバネストッパー	Thread take-up spring stopper						
19	M9 0907 002	W500076	平 ネ ジ 9/64(40)×5	Screw (for Fig. 18) 9/64(40)×5						
20	ML 65B0 192	W466213	板 バ ネ	Leaf spring						
21	M9 9006 002	W500791	平 ネ ジ 9/64(40)×1.5	Screw (for Fig. 20) 9/64(40)×4.5						
22	ML 65B0 603	W326247	針 板 取 付 台	Needle plate set base						
23	M9 0907 002	W500076	平 ネ ジ 9/64(40)×5	Screw (for Fig. 22) 9/64(40)×5						
24	ML 65B0 229	W464402	内 ガ マ 止 メ	Hook Stopper						
25	M9 0601 010	W500654	皿 ネ ジ 3/32(56)×2.5	Screw (for Fig. 24) 3/32(56)×2.5						
26	ML 65B0 339	W464088	カ マ カ バ ー	Hook cover						
27	ML 65B0 101	W464403	針 板	Needle Plate						
28	M9 0904 011	W500147	丸 皿 ネ ジ 9/64(40)×6.5	Screw (for Fig. 27) 9/64(40)×6.5						
29	MP 00B0 181	W456528	糸 カ ケ	Thread guide						
30	MP 00B0 740	W502486	フ ェ ル ト	Felt						
31	M9 0920 002	W501523	平 ネ ジ 9/64(40)×6.5	Screw (for Fig. 29) 9/64(40)×6.5						
32	M9 0904 011	W500147	丸 皿 ネ ジ 9/64(40)×6.5	Screw (for Fig. 33) 9/64(40)×6.5						
33	MN 10A1 181	W445858	糸 カ ケ	Thread guide						
34	MP 00B0 605	W445862	面 板 止 メ バ ネ	Face plate spring						
35	MN 10A0 476	W445874	座 板	Plate washer						
36	M9 0503 063	W500989	ピ ン 5φ×7	Face plate stopper pin						
37	MN 12B0 830	W220608	面 板	Face plate						
38	M9 0504 063	W445860	面 板 支 エ 軸 5φ×60	Face plate hinge pin						

CU-865形 上糸調節器関係 THREAD TENSION REGULATOR CPL

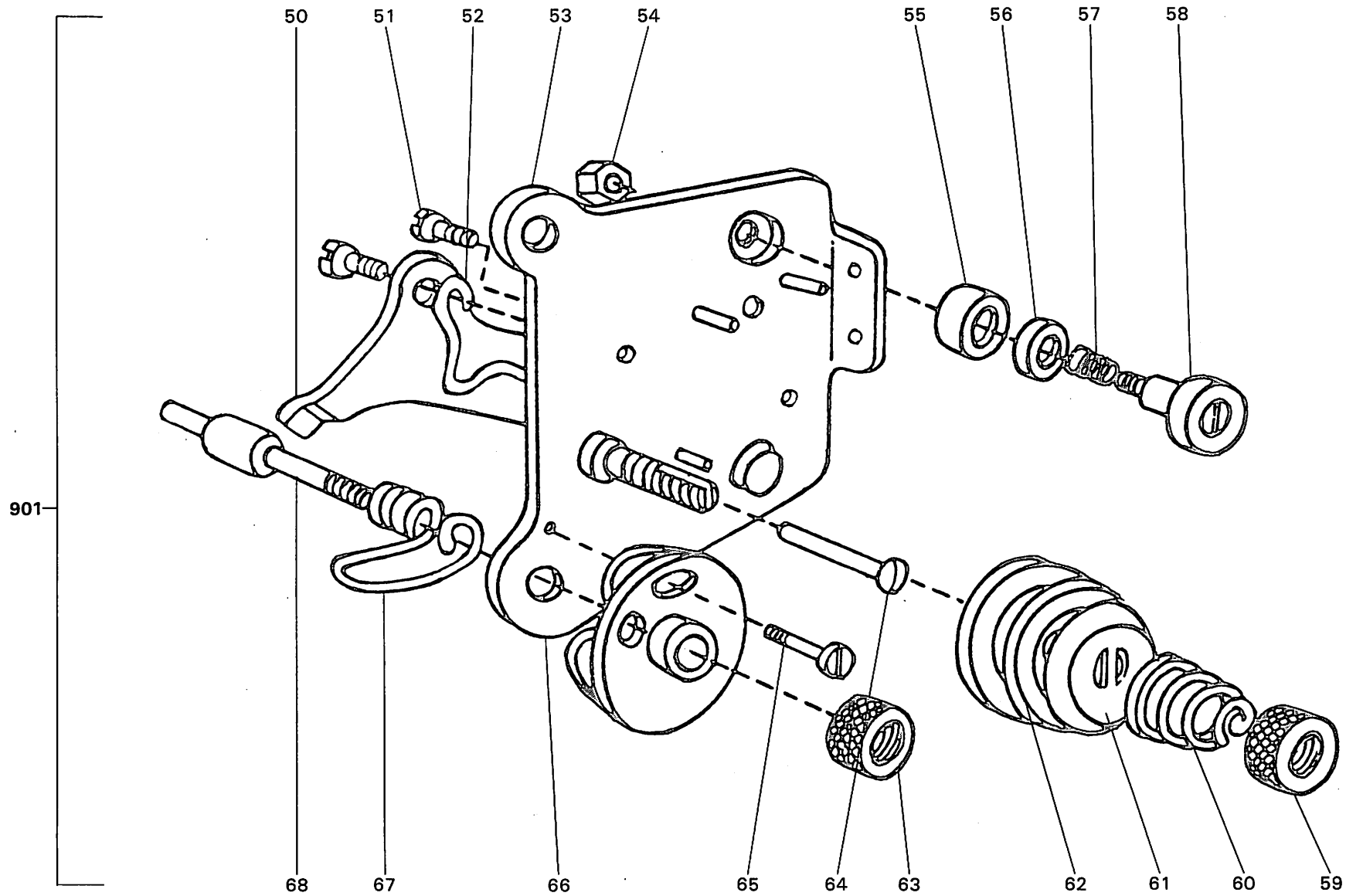

＜CU-865形＞ 上糸調節器関係 THREAD TENSION REGULATOR CPL

Fig. No.	サービス部品コード Part No.	資材コード Code No.	部 品 名	Name of Part	個 / 台 Amt. req				備 考 Remarks
901	ML 65E0 210	W451952	上糸調節器 (組)	Tension bracket cpl.					
50		W450020	糸 ユルメ板	Tension release lever					Fig.No.901ニ含ム
51	M9 0902 015	W501026	段付平ネジ 9/64(40)×6	Screw (for Fig. 50)					//
52	MN 10A0 851	W502148	戻 シ バ ネ	Spring (for Fig. 50)					//
53		W462908	糸 加 減 座	Tension bracket					//
54	M9 0901 045	W500307	ナ ッ ト 9/64(40)×2.5	Nut 9/64(40)					//
55	MN 10A0 155	W502213	糸 案 内 台	Thread guide base					//
56	MN 10A1 555	W502212	糸 案 内 皿	Thread guide disc					//
57	MN 10A1 572	W502065	上糸案内調子バネ	Thread tension spring					//
58	M9 0930 016	W462822	段付丸平ネジ 9/64(40)	Stud screw					//
59	M9 1603 046	W502940	調子ナット 1/4(40)×4.5	Thread tension regulating thumb nut 1/4(40)					//
60	MF 23C0 245	W461786	調子バネ	Thread tension spring					//
61	MN 10A0 556	W445934	皿 押 エ	Thread tension releasing disc					//
62	MN 10A0 555	W445933	調子皿	Thread tension disc					//
63	M9 1603 046	W502940	調子ナット 1/4(40)×4.5	Tension thumb nut 1/4(40)					//
64	M9 0202 060	W502064	糸ユルメピン(小) 2φ×12	Thread tension releasing pin					//
65	M9 0602 003	W501057	丸平ネジ 3/32(56)×6	Screw (for Fig. 66) 9/64(40) × 6					//
66	MN 10E0 175	W462825	糸案内車	Thread controller disc					//
67	MP 00B0 187	W456524	糸取りバネ	Thread take-up spring					//
68	MN 10A0 554	W450011	糸調子軸	Thread tension stud					//

CU-865形 押え関係 PRESSER FOOT MECHANISM

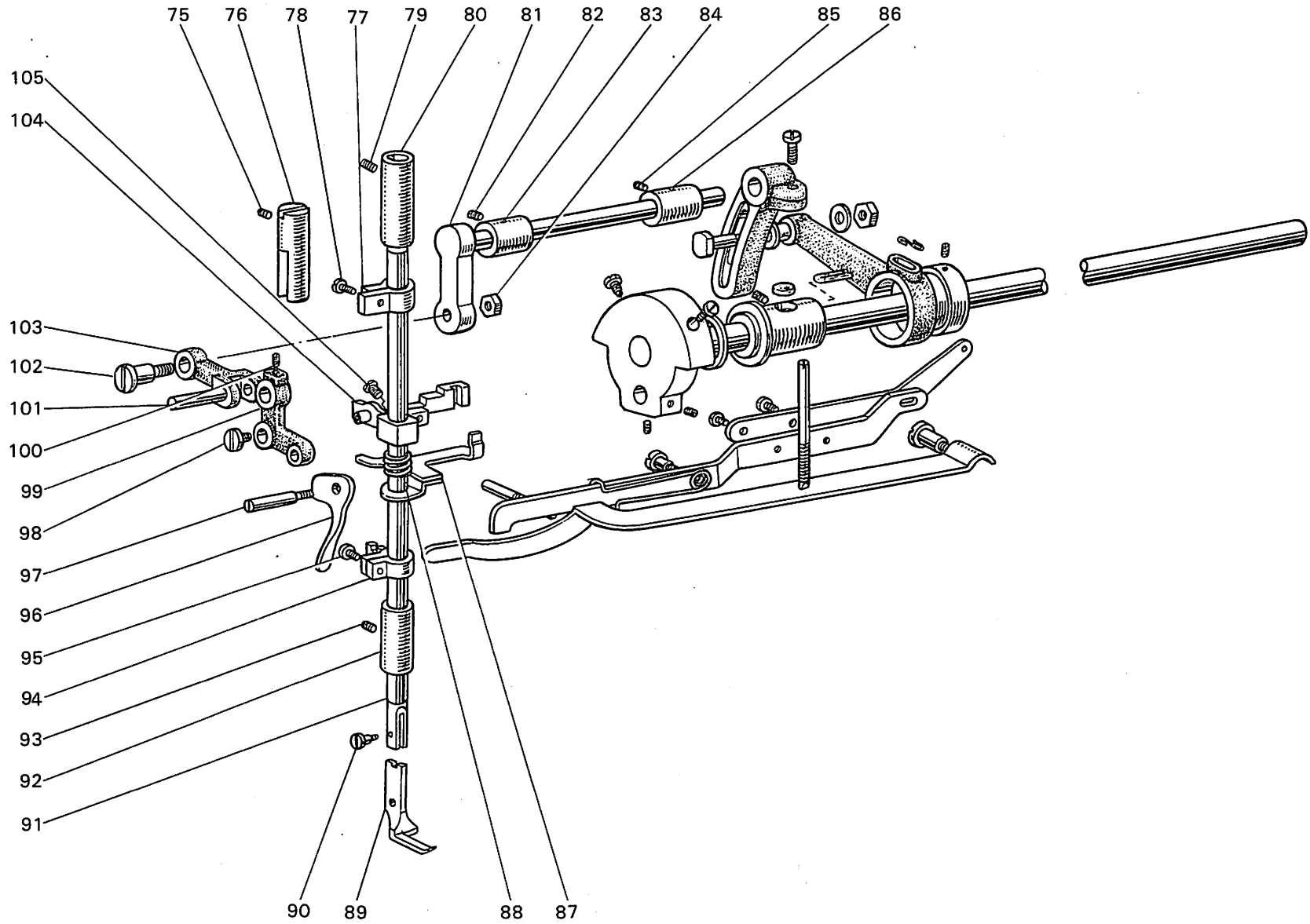

<CU-865形> 押え関係 PRESSER FOOT MECHANISM

Fig. No.	サービス部品コード Part No.	資材コード Code No.	部 品 名	Name of Part	個 / 台 Amt. req					備 考 Remarks
75	M9 1653 001	W500478	頭ナシ止メネジ 1/4(24)×8	Set screw (for Fig. 76) 1/4(24) × 7						
76	MN 10A0 203	W445918	押エ棒案内	Presser bar position guide						
77	MN 10A0 265	W445920	押エ棒ダキ	Presser bar position guide lever						
78	M9 0903 003	B 509268	丸平ネジ 9/64(40)×10	Screw 9/64(40) × 10						
79	M9 1653 001	W500478	頭ナシ止メネジ 1/4(24)×8	Set screw (for Fig. 80) 1/4(24) × 7						
80	MN 10A0 267	W445929	押エ棒メタル	Presser bar bushing (upper)						
81	MP 00B0 268	W461762	押エ上下軸	Lifting rock shaft						
82	M9 1653 001	W500478	頭ナシ止メネジ 1/4(24)×8	Set screw 1/4(24) × 7						
83	MG 10B0 833	W502463	メタル	Shaft bushing						
84	M9 1802 045	B 508961	ナット 9/32(28)×3.5	Nut 9/32(28)						
85	M9 1653 001	W500478	頭ナシ止メネジ 1/4(24)×8	Set screw (for Fig. 86) 1/4(24) × 7						
86	MG 10B0 833	W502463	メタル	Shaft bushing						
87	MP 00B0 221	W322744	上糸ユルメ板	Tention releasing plate						
88	MP 00B0 572	W502465	ツル巻キバネ	Spring						
89	ML 65B0 106	W464406	外押エ	Outside presser foot						
90	M9 0851 015	W501007	段付平ネジ 1/8(44)×9	Screw (for Fig. 89)						
91	MN 10A0 262	W445919	押エ棒	Presser bar						
92	MN 10A0 267	W445929	押エ棒メタル	Presser bar bushing lower						
93	M9 1653 001	W500478	頭ナシ止メネジ 1/4(24)×8	Set screw 1/4(24) × 7						
94	MN 10A0 702	W445921	バネ受ケ	Presser bar spring bracket						
95	M9 0905 002	W500470	平ネジ 9/64(40)×8.5	Screw (for Fig. 94) 9/64(40) × 8.5						
96	MN 10A0 252	W459307	押エ上ゲ	Presser bar lifter						
97	M9 1201 033	W501024	ピンネジ 3/16(28)×24.5	Hinge screw (for Fig. 96)						
98	M9 1151 003	W502454	丸平ネジ 11/64(32)×6	Screw (for Fig. 99) 11/64(32) × 6						
99	MP 00B0 763	W322716	ベルクランク	Bell crank						
100	M9 1202 001	W500151	頭ナシ止メネジ 3/16(28)×6	Set screw (for Fig. 99) 3/16(28) × 5						
101	M9 0602 060	W462916	ピン 0.35φ×17.6	Pin						
102	M9 1805 015	W502398	段付平ネジ 9/32(28)×23.5	Screw						
103	MP 00B0 910	W507414	リンク	Bell crank link						
104	MP 00B0 764	W322717	ベルクラン土台	Bell crank bed						
105	M9 1113 002	W500182	平ネジ 11/64(40)×15	Screw (for Fig. 104) 11/64(40) × 15						

CU-865形 上軸押え上げ関係 ARM SHAFT & KNEE LIFTER LIFTING LEVER MECHANISM

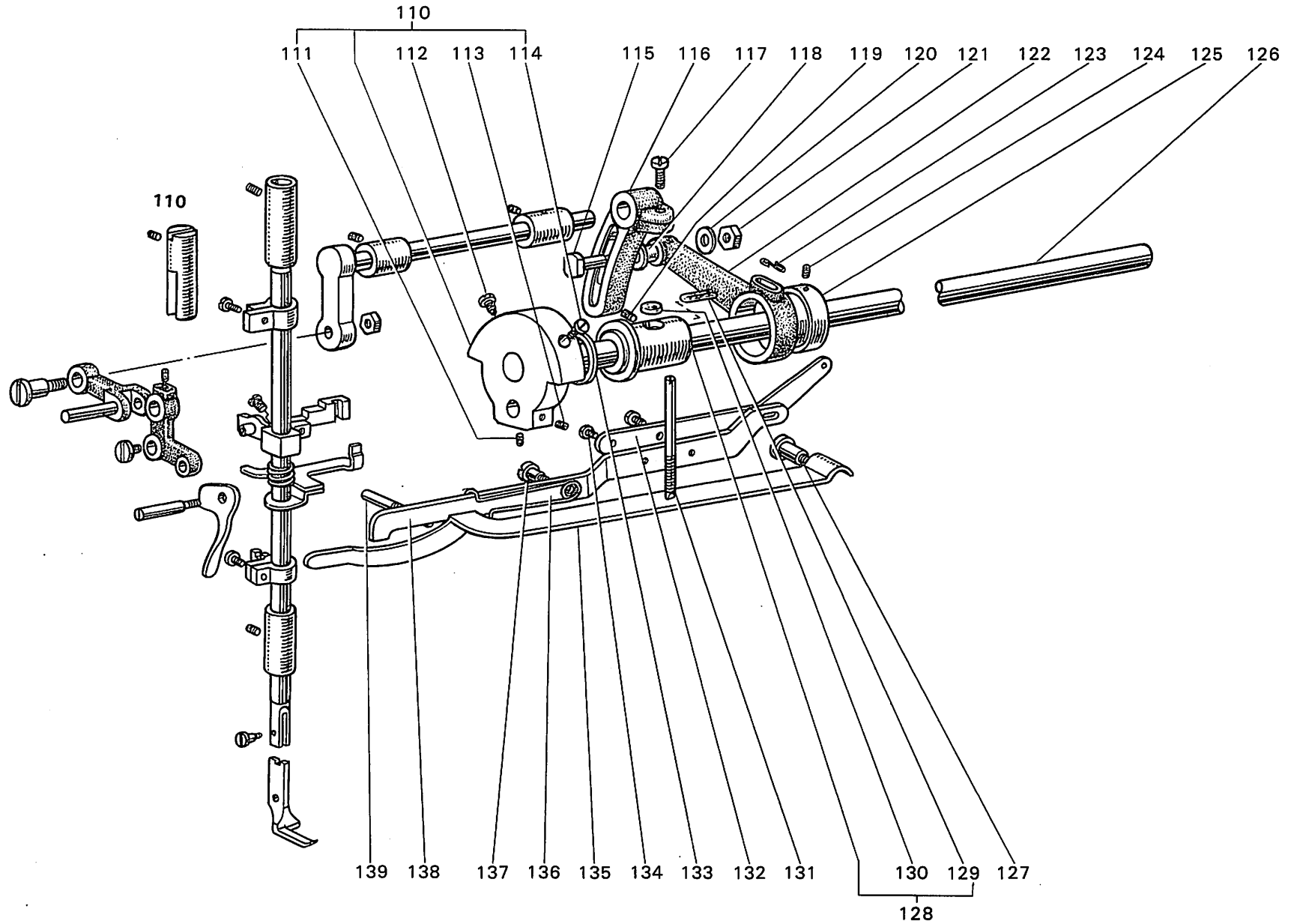

<CU-865形> 上軸押え上げ関係 ARM SHAFT & KNEE LIFTER
LIFTING LEVER MECHANISM

Fig. No.	サービス部品コード Part No.	資材コード Code No.	部 品 名	Name of Part	個 / 台 Amt. req						備 考 Remarks	
110	ML 65B0 383	W464419	ク ラ ン ク	Crank								
111	M9 1502 001	B 500486	頭ナシ止メネジ 15/64(28)×3.5	Set screw 15/64(28) ×3.5								
112	M9 1801 002	W500306	平 ネ ジ 9/32(28)×13	Screw 9/32(28) ×13								
113	M9 1508 001	B 504016	頭ナシ止メネジ 15/64(28)×8	Set screw 15/64(28) ×7								
114	M9 1802 006	B 503851	棒 先 平 ネ ジ 9/32(28)×14	Set screw 9/32(28)								
115	MG 10B0 325	W502416	角 駒	Square block								
116	MP 00B0 462	W453576	上部上下送り腕	Feed lifting rock shaft crank								
117	M9 1603 003	W501009	丸 平 ネ ジ 1/4(24)×16	Screw (for Fig. 116) 1/4(24) ×16								
118	MG 10B0 750	W462911	ブ ッ シ ュ	Bush (for Fig. 122)								
119	M9 1654 001	W501017	頭ナシ止メネジ 1/4(24)×13.8	Set screw (for Fig. 128) 1/4(24) ×13								
120	M9 0607 050	W462759	座 金 M6	Washar (for Fig. 122)								
121	M9 1601 045	W501989	ナ ッ ト 1/4(24)×3.5	Nut (for Fig. 122) 1/4(24)								
122	MG 10B0 384	W453577	クランクロッド	Crank rod								
123	MF 60A0 700	W500836	バ ネ	Spring (for Fig. 122)								
124	M9 1606 001	B 504016	頭ナシ止メネジ 1/4(40)×7	Set screw (for Fig. 125) 1/4(40) ×6								
125	MG 10B0 760	W453531	偏 心 輪	Lifting eccentric								
126	ML 65B0 230	W326244	上 軸	Arm shaft								
127	M9 1602 016	W501006	段付丸平ネジ 1/4(24)×29	Presser bar spring support screw								
128	ML 65B0 232	W464462	上軸メタル (左)	Arm shaft bushing(Left)								
129	MF 10E1 148	W462914	毛 糸	Yarn								
130	MN 10A2 740	W501204	フ ェ ル ト	Felt (for Fig. 128)								
131	M9 1601 033	W445917	押エ調節ネジ 1/4(40)×78	Presser bar spring regulating screw 1/4(40)								
132	MM 11A0 255	W453571	押エ上ゲ板	Lifting lever								
133	MN 10A0 482	W445867	リ ン グ	Friction washer								
134	M9 1208 002	W500202	平 ネ ジ 3/16(28)×10.5	Screw (for Fig. 132) 3/16(28) ×10.5								
135	MN 10A0 258	W319992	押エ板バネ	Presser bar spring (flat)								
136	MM 11A0 729	W445300	ヒネリバネ	Knee lifter lifting lever return spring								
137	M9 1601 016	W501020	段付丸平ネジ 1/4(24)×14	Hinge screw								
138	MP 00B0 725	W453590	ヒザ上ゲテコ	Knee lifter lifting lever								
139	ML 65B0 477	W501024	ストッパー	Stopper								

CU-865形 針棒搖動關係 NEEDLE BAR ROCK SHAFT MECHANISM

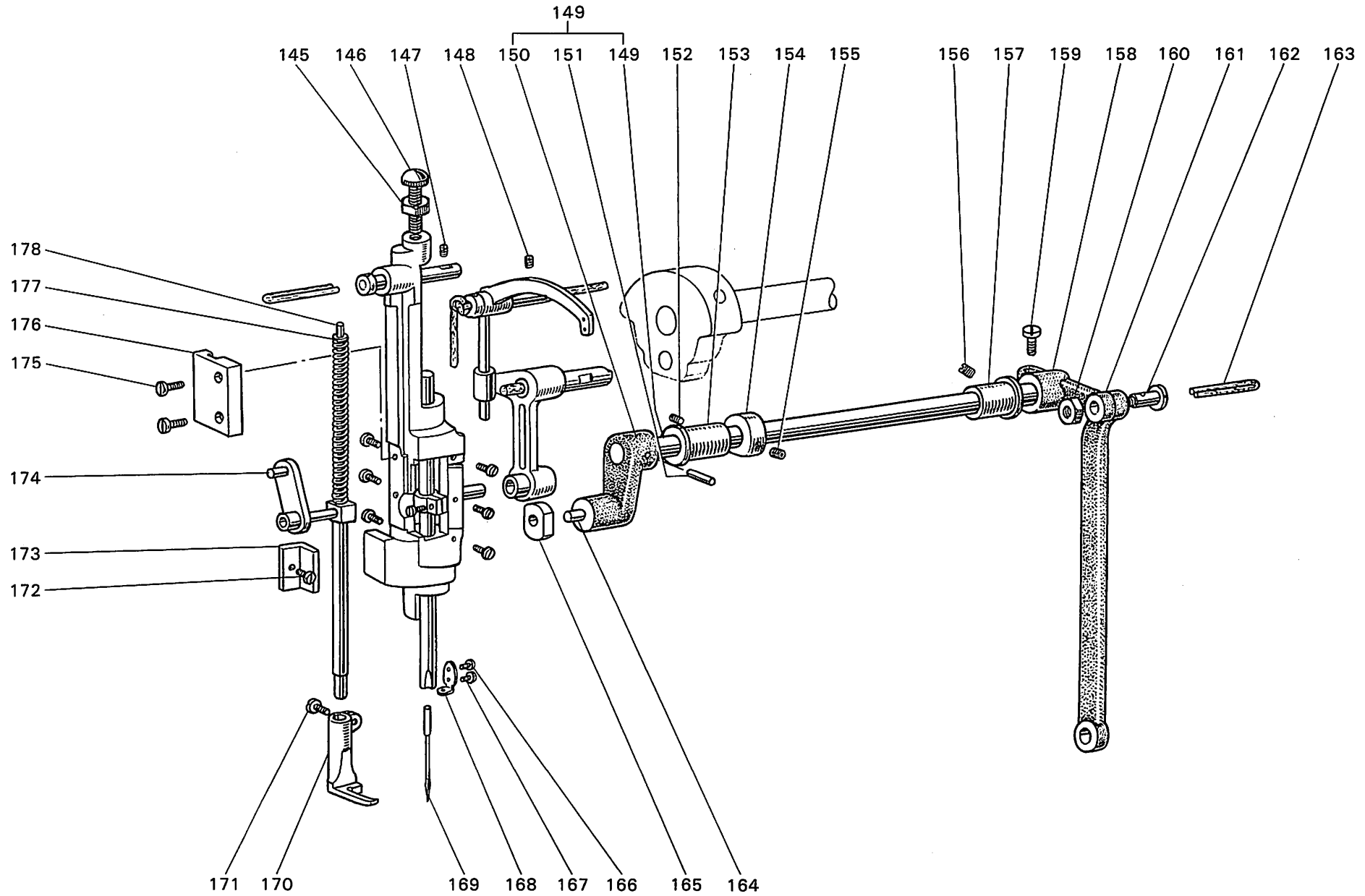

<CU-865形> 針棒揺動関係

NEEDLE BAR ROCK SHAFT MECHANISM

Fig. No.	サービス部品コード Part No.	資材コード Code No.	部 品 名	Name of Part	個 / 台 Amt. req						備 考 Remarks
145	M9 1251 045	B 509177	ナ ッ ト 3/16(32)×3	Nut(for Fig. 146) 3/16(32)							
146	M9 1201 035	W502464	ツ マ ミ ネ ジ 3/16(32)×39	Thumb screw							
147	M9 1506 001	B 509087	頭ナシ止メネジ 15/64(28)×7	Set screw 15/64(28) ×6							
148	M9 1502 002	W500509	平 ネ ジ 15/64(28)×12	Set screw 15/64(28) ×11							
149	ML 65B0 668	W465662	針 棒 揺 動 軸	Needle bar rock frame rocking shaft							
150	MP 00B0 672	W453583	針棒揺動腕 (左)	Needle bar rock arm (left)							
151	M9 0401 061	W501209	テ ー パ ー ピ ン 4φ×23×1/50	Taper pin							
152	M9 1653 001	W500478	頭ナシ止メネジ 1/4(24)×8	Set screw 1/4(24)×7							
153	MN 10A0 669	W462919	針棒揺動軸メタル (左)	Needle bar rock shaft bushing							
154	ML 65B0 352	W464068	カ ラ ー	Collar							
155	M9 1601 020	W462662	六角孔付止メネジ 1/4(40)×6	Socket screw							
156	M9 1653 001	W500478	頭ナシ止メネジ 1/4(24)×8	Set screw 1/4(24) ×7							
157	MN 10A1 669	W445871	針棒揺動軸メタル (右)	Needle bar rock shaft bushing (right)							
158	ML 65B0 672	W464410	針 棒 揺 動 腕 (右)	Needle bar rock arm (right)							
159	M9 1603 003	W501009	丸 平 ネ ジ 1/4(24)×16	Screw 1/4(24) ×16							
160	M9 2002 045	W501187	ナ ッ ト 5/16(24)×5.5	Nut 5/16(24)							
161	MP 00B0 671	W453585	針棒揺動連結桿	Needle bar rock shaft connection link crank							
162	M9 2001 015	W501010	段 付 平 ネ ジ 5/16(24)×26.2	Screw							
163	MF 10E2 148	W462978	油 ヒ モ 2.5φ×85	Wick							
164	M9 0509 063	W502445	揺 動 ピ ン 15/64(28)×24	Pin(for Fig. 150)							
165	MN 25A0 325	W502443	角 駒	Square block							
166	M9 0602 002	W501567	平 ネ ジ 3/32(56)×3	Screw 3/32(56) ×3							
167	M9 0801 002	W501391	平 ネ ジ 1/8(44)×3	Needle clamp screw 1/8(44) ×4.4							
168	MP 00B1 181	W457584	針 棒 糸 カ ケ	Needle bar thread guide							
169	MF 22B0 128	DP×17 #21	針 DP×17 #21	Needle							
170	ML 65B0 107	W464405	内 押 エ	Inside presser foot							
171	M9 0907 002	W500076	平 ネ ジ 9/64(40)×5	Screw (for Fig. 170) ×9/64(40) ×5							
172	M9 1105 002	W500450	平 ネ ジ 11/64(40)×10	Screw 11/64(40) ×8							
173	MP 00B0 667	W453582	針棒支エガイド	Needle bar rock frame guide							
174	M9 00B0 882	W453587	揺動押エ棒リンク	Vibrating presser bar connecting link							
175	M9 1113 002	W500182	平 ネ ジ 11/64(40)×15	Screw (for Fig. 176) 11/64(40) ×15							
176	MP 00B0 883	W453581	揺動押エ棒案内	Vibrating presser bar guide							
177	MH 19A0 259	W462921	押 エ バ ネ	Extension spring							
178	MP 00B0 884	W453589	揺動押エバネ案内	Vibrating presser bar extension							

CU-865形 天秤 針棒支え関係 NEEDLE BAR ROCK FRAME & THREAD TAKE-UP MECHANISM

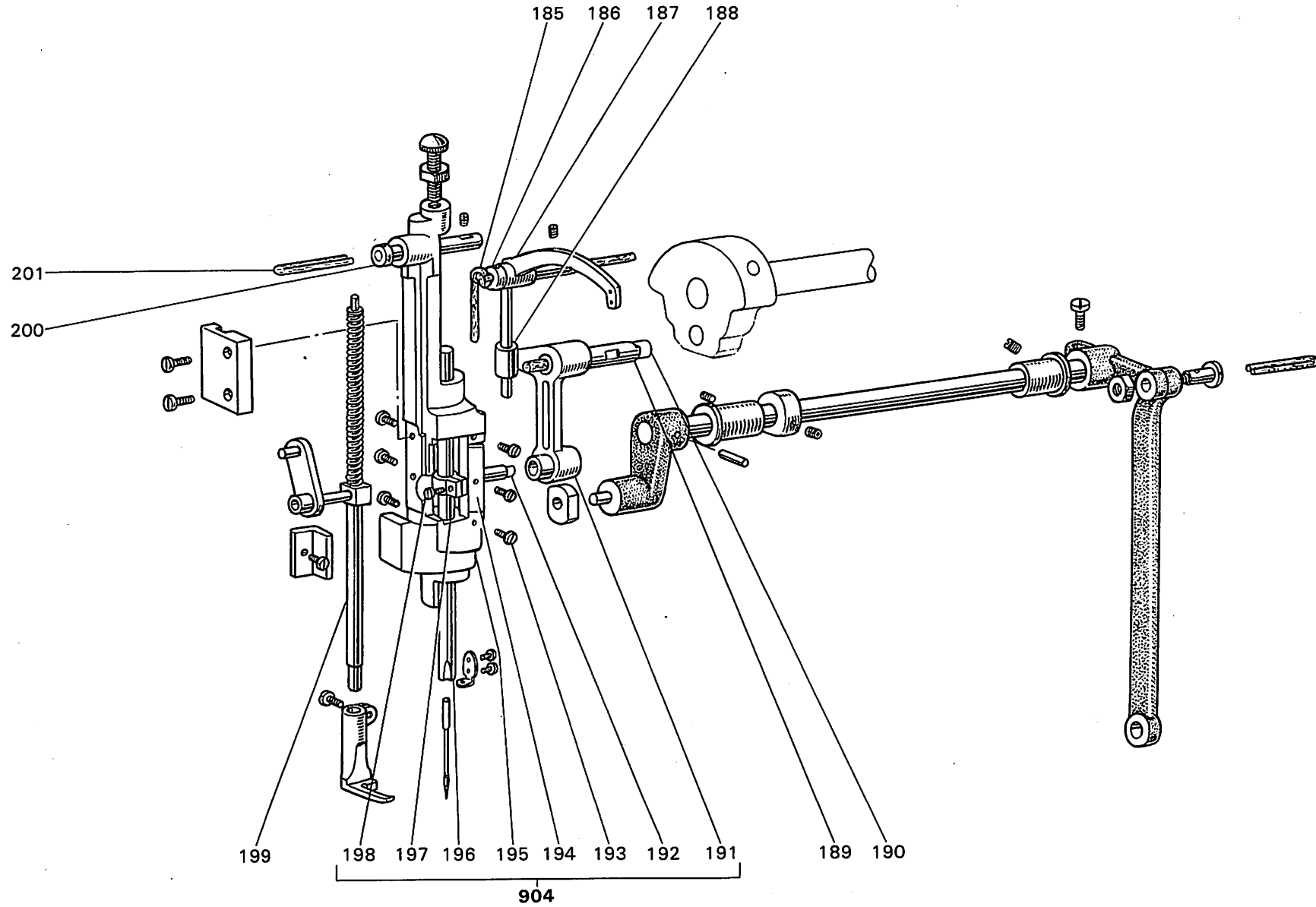

<CU-865形> 天秤・針棒支え関係 NEEDLE BAR ROCK FRAME & THREAD TAKE-UP MECHANISM

Fig. No.	サービス部品コード Part No.	資材コード Code No.	部 品 名	Name of Part	個 / 台 Amt. req					備 考 Remarks
185	MF 10E2 148	W444138	油 ヒ モ 2.5φ×240	Oil wick						
186	M9 0710 063	W445883	支 エ 軸 7.94φ×36	Take-up lever hinge stud						
187	MP 00B0 582	W462789	天 秤	Thread take-up lever						
188	MN 10A0 588	W445881	天 秤 ス ベ リ	Take-up lever driving stud						
189	MN 10A0 387	W445866	ク ラ ン ク ピ ン	Crank pin						
190	MN 10A1 740	W500801	フ ェ ル ト	Felt (for Fig. 189)						
904	ML 65E0 666	W326220	針 棒 支 工 (組)	Needle bar rock frame cpl.						
191	MP 00B0 661	W326221	針棒クランクロッド	Needle bar connecting link						Fig.No.904ニ含ム
192	MN 10A0 740	W500499	フ ェ ル ト	Felt (for Fig. 197)						
193	M9 0604 011	W501205	丸 皿 ネ ジ 3/32(56)×4	Screw (for Fig. 194) 3/32(56) ×4						Fig.No.904ニ含ム
194	MP 00B0 476	W454800	ス ペ ー サ	Spacer						//
195	MP 00B0 666	W220605	針 棒 支 工	Needle bar rock frame						//
196	MP 00B0 660	W446382	針 棒	Needle bar						//
197	MP 00B0 665	W462920	針 棒 ダ キ	Needle bar connecting stud						//
198	M9 0905 002	W500470	平 ネ ジ 9/64(40)×8.5	Screw (for Fig. 197) 9/64(40) ×8.5						//
199	MP 00B0 881	W453588	揺 動 押 工 棒	Vibrating presser bar						
200	MN 10A0 587	W445883	支 工 軸	Hinge stud (for Fig. 195)						
201	MF 10E2 148	W462979	油 ヒ モ 2.5φ×80	Oil wick (for Fig. 200)						

CU-865形 送り調節器関係 STITCH LENGTH REGULATOR MECHANISM

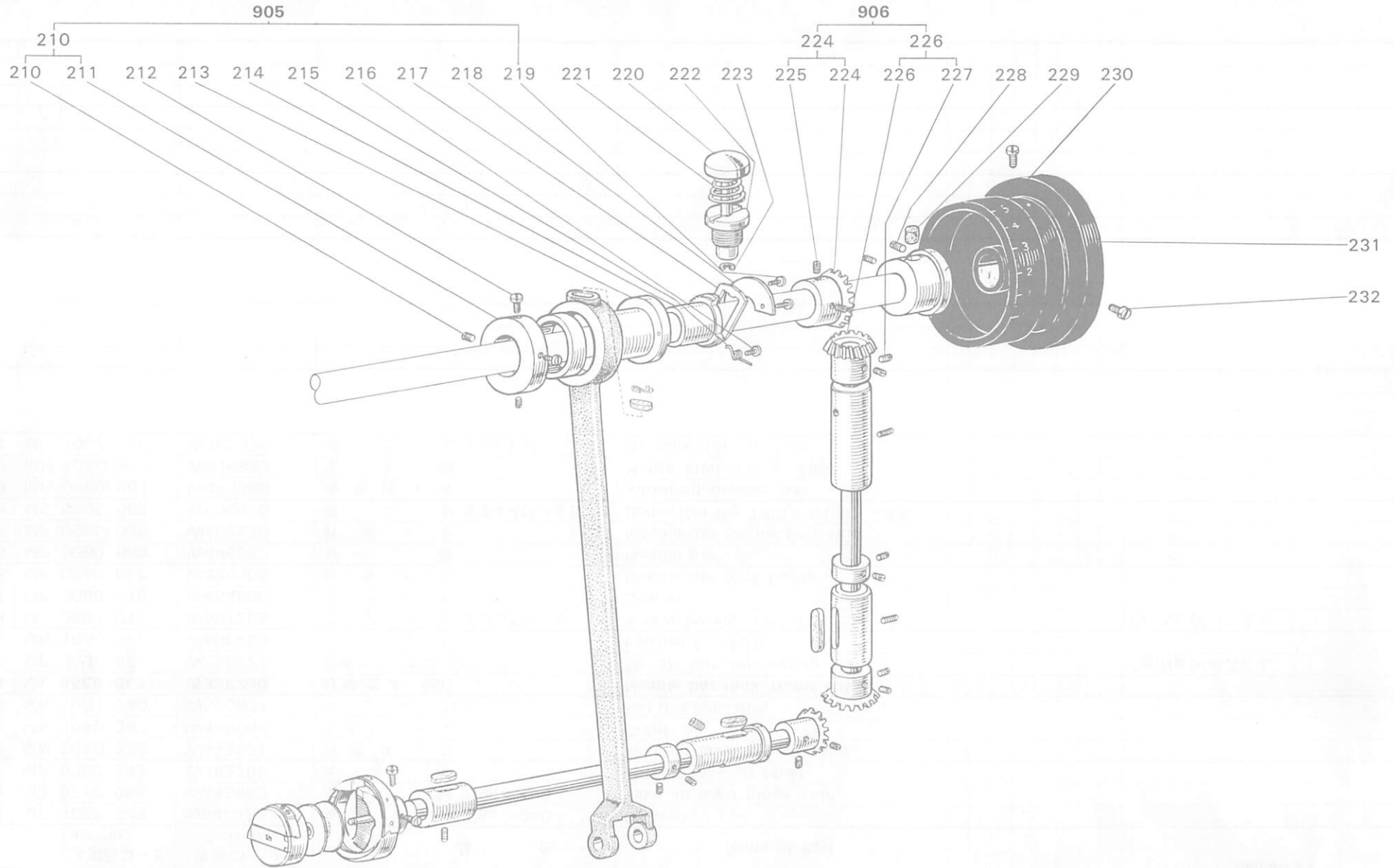

<CU-865形> 送り調節器関係 STITCH LENGTH REGULATOR MECHANISM

Fig. No.	サービス部品コード Part No.	資材コード Code No.	部 品 名	Name of Part	個 / 台 Amt. req					備 考 Remarks
905	ML 65E0 290	W464072	送り調節器 (組)	Feed regulator complete						
210		W450960	カ ラ ー	Feed lifting cam						Fig.No.905ニ含ム
211	M9 1511 001	W500706	頭ナシ止メネジ 15/64(28)×9.5	Set screw (for Fig. 210) 15/64(28) ×9						//
212	M9 1501 002	W500945	平 ネ ジ 15/67(28)×8.5	Set screw (for Fig. 210) 15/64(28) ×8.5						//
213		W464460	駆 動 輪	Feed rock shaft can						//
214		W464073	偏 心 輪	Eccentric ring						//
215		W501163	ヒ ネ リ バ ネ	Spring (for Fig. 217)						//
216	M9 0901 015	W501162	段 付 平 ネ ジ 9/64(40)×11.3	Screw (for Fig. 215)						//
217		W446370	ク ラ ッ チ 板	Clutch plate (for Fig. 214)						//
218		W446371	カ バ ー 板	Cover plate (for Fig. 213)						//
219	M9 0906 002	W500791	平 ネ ジ 9/64(40)×4.5	Screw (for Fig. 218) 9/64(40) ×4.5						//
220	ML 65B0 270	W464074	押 シ ボ タ ン	Push button (for feed regulator)						
221	MF 30A0 245	W462657	円 錐 バ ネ	Spring (for Fig. 220)						
222	ML 65B0 750	W464064	ブ ッ シ ュ	Bushing (for Fig. 220)						
223	M9 0505 065	W461793	止 メ 輪 E5	Snap-ring (for Fig. 220)						
906	MF 10E0 335	W462638	傘 歯 車 (組)	Feed regulating push button complete						
224	MF 10A0 331	W444106	傘 歯 車 (上軸)	Bevel gear (arm shaft)						Fig.No.906ニ含ム
225	M9 1606 001	B 504016	頭ナシ止メネジ 1/4(40)×7	Set screw (for Fig. 224) 1/4(40) ×6						//
226	MF 10A0 333	W444107	傘 歯 車 (堅上)	Bevel gear (vertical shaft upper)						//
227	M9 1606 001	B 504016	頭ナシ止メネジ 1/4(40)×7	Set screw (for Fig. 226) 1/4(40) ×6						//
228	M9 1654 001	W501017	頭ナシ止メネジ 1/4(24)×13.8	Set screw 1/4(40) ×12						
229	MN 10A2 740	W500619	フ ェ ル ト	Felt (for Fig. 230)						
230	ML 65B0 231	W464065	上 軸 メ タ ル	Arm shaft bushing (back)						
231	MM 11A0 682	W453501	ハ ズ ミ 車	Balance wheel						
232	M9 1502 002	W500509	平 ネ ジ 15/64(28)×12	Set screw (for Fig. 231) 15/64(28) ×12						

CU-865形 豎軸・下軸關係
VERTICAL SHAFT & ROTATING HOOK
SHAFT MECHANISM

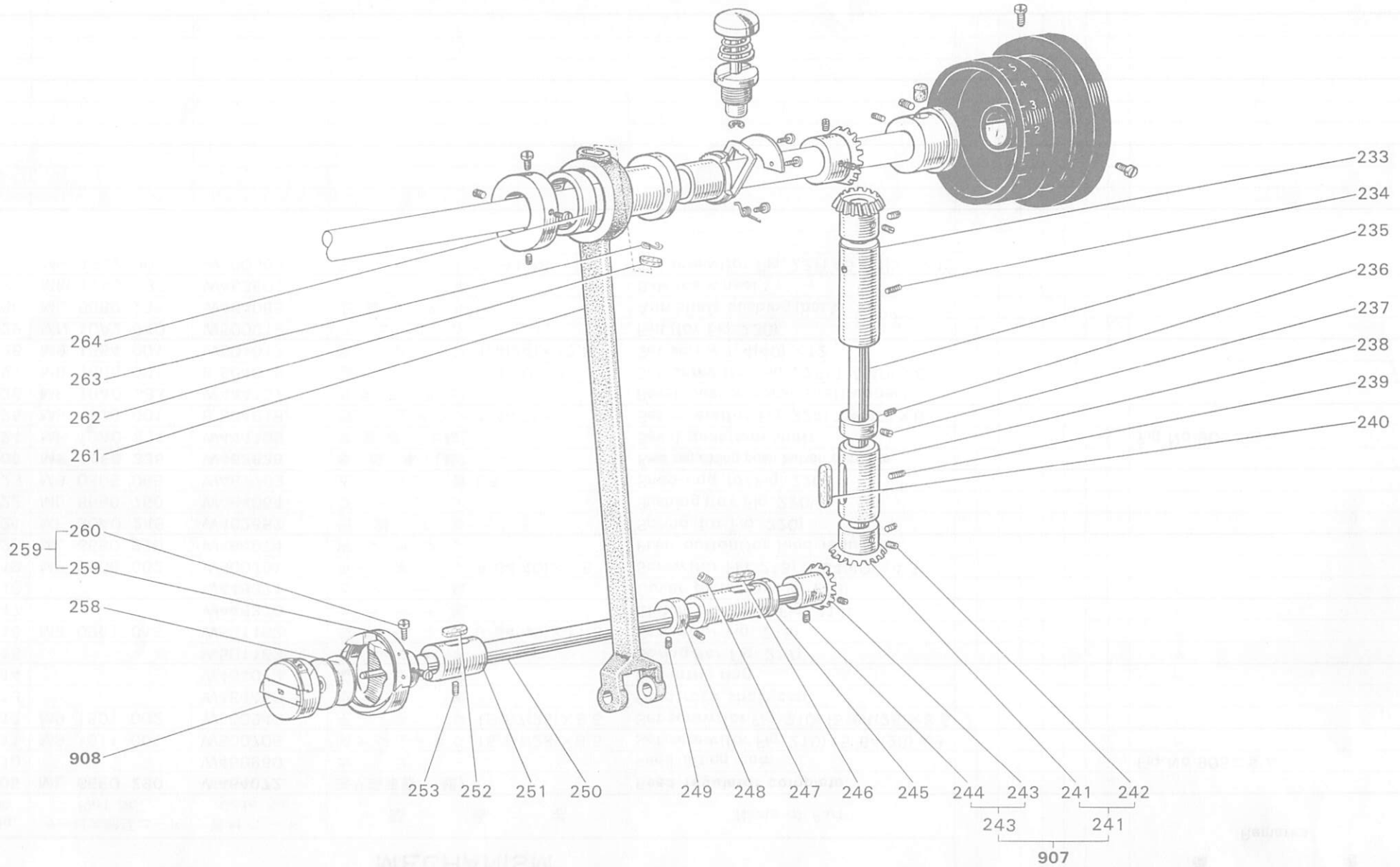

<CU-865形> 堅軸・下軸関係 VERTICAL SHAFT & ROTATING HOOK SHAFT MECHANISM

Fig. No.	サービス部品コード Part No.	資材コード Code No.	部 品 名	Name of Part	個 / 台 Amt. req					備 考 Remarks
233	ML 65B0 521	W464071	堅軸メタル (上)	Vertical shaft bushing (upper)						
234	M9 1513 001	B 509060	頭ナシ止メネジ 15/64(28)×11	Set screw (for Fig. 233) 15/64(28)×10						
235	ML 65B0 520	W464070	堅 軸	Vertical shaft						
236	MF 10A0 352	B 422844	カ ラ ー	Vertical shaft collar						
237	M9 1503 001	B 508971	頭ナシ止メネジ 15/64(28)×4.5	Set screw (for Fig. 236) 15/64(28) ×4						
238	MF 67B0 522	W462734	堅軸メタル (下)	Vertical shaft bushing (under)						
239	M9 1513 001	B 509060	頭ナシ止メネジ 15/64(28)×11	Set screw (for Fig. 238) 15/64(28) ×10						
240	MF 60A3 740	W500956	フ ェ ル ト	Felt (for Fig. 238)						
907	MF 10E0 336	W462637	傘 歯 車 (組)	Hook shaft bevel gear complete						
241	MF 10A0 334	W444109	傘 歯 車 (堅下)	Bevel gear (vertical shaft under)						Fig.No.907ニ含ま
242	M9 1606 001	B 504016	頭ナシ止メネジ 1/4(40)×7	Set screw (for Fig. 741) 1/4(40)×6						//
243	MF 60A0 332	W462639	傘 歯 車 (下軸)	Bevel gear (hook shaft)						//
244	M9 1606 001	B 504016	頭ナシ止メネジ 1/4(40)×7	Set screw (for Fig. 243) 1/4(40)×6						//
245	ML 65B0 452	W464085	下軸メタル (右)	Rotating hook shaft bushing (right)						
246	MG 30B0 740	W464014	フ ェ ル ト	Felt (for Fig. 245)						
247	M9 1508 001	B 509088	頭ナシ止メネジ 15/64(28)×8	Set screw (for 245) 15/64(28) ×8						
248	MF 60A0 352	W461790	カ ラ ー	Rotating hook shaft collar						
249	M9 1503 001	B 508971	頭ナシ止メネジ 15/64(28)×4.5	Set screw (for Fig. 248) 15/64(28) ×4						
250	ML 65B0 450	W464084	下 軸	Rotating hook shaft						
251	ML 65B0 451	W464086	下軸メタル (左)	Rotating hook shaft bushing (left)						
252	MG 30B0 740	W464014	フ ェ ル ト	Felt (for Fig. 251)						
253	M9 1513 001	B 509060	頭ナシ止メネジ 15/64(28)×11	Set screw (for Fig. 251) 15/64(28) ×10						
908	MF 10E0 125	W461742	ボビンケース(組)	Bobbin case complete						
258	MF 10A0 123	W462632	ボ ビ ン	Bobbin						
259	ML 65B0 120	B 209053	カ マ DB1-Z14	Rotating hook						
260	M9 1102 002	W500193	平 ネ ジ 11/64(40)×8.5	Set screw (for Fig. 259) 11/64(40) ×4						
261	ML 65B0 384	W326245	クランクロッド	Feed rock shaft crank rod						
262	MF 60A1 740	W500738	フ ェ ル ト	Felt (for Fig. 261)						
263	MF 60A0 700	W500836	バ ネ	Spring (for Fig. 261)						
264	M9 0103 070	W462946	ニードルローラベアリング	Needle roller bearing						

CU-865形 返し縫い関係 REVERSE SEWING MECHANISM

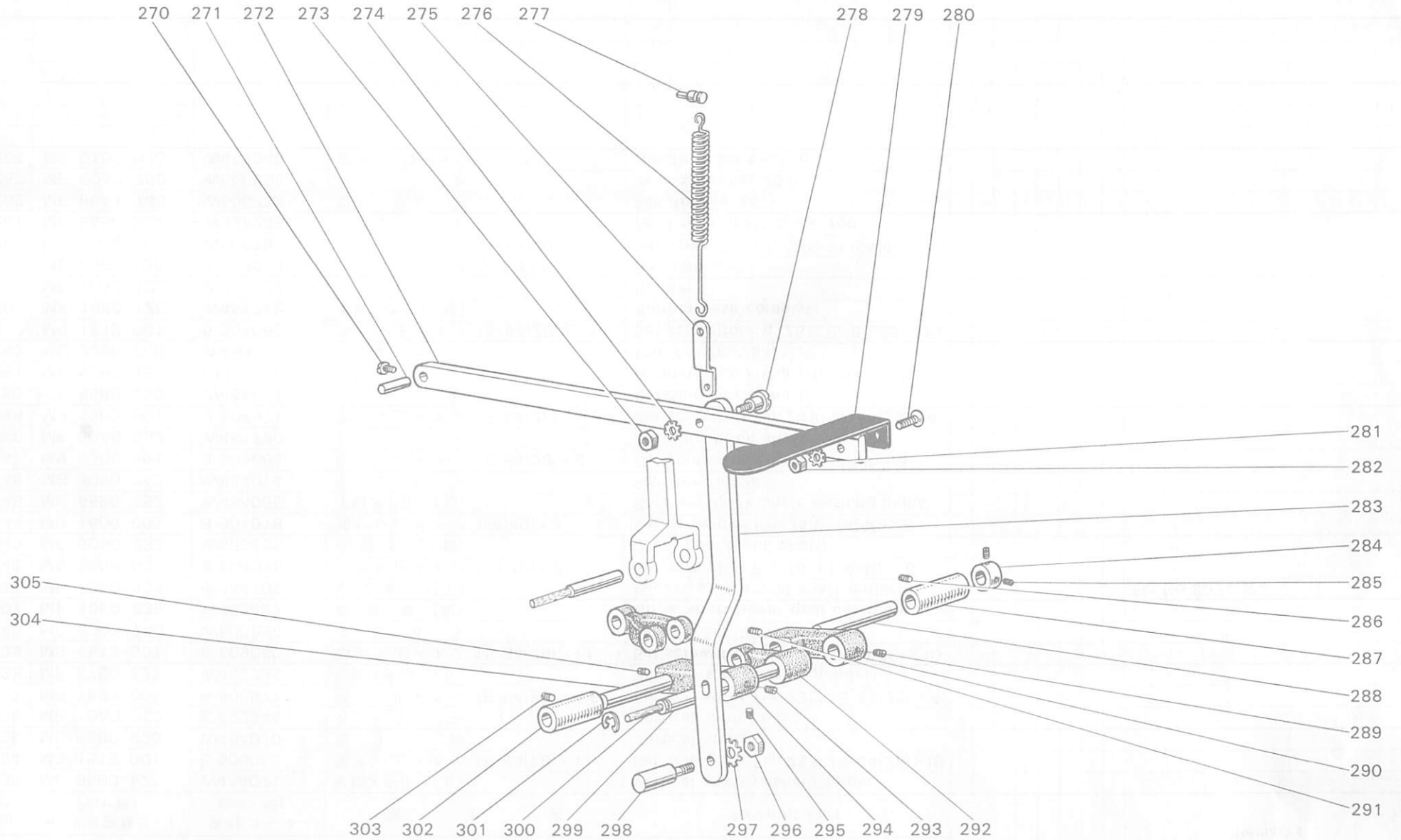

<CU-865形> 返し縫い関係 REVERSE SEWING MECHANISM

Fig. No.	サービス部品コード Part No.	資材コード Code No.	部 品 名	Name of Part	個 / 台 Amt. req						備 考 Remarks
270	M9 0903 002	B 509065	平 ネ ジ 9/64(40)×6.5	Screw (for Fig. 213) 9/64(40)×6.5							
271	M9 0604 060	W502791	ピ ン 6.35φ×20	Pin (for Fig. 272)							
272	ML 65B0 322	W464076	返シ縫イテコ	Feed reversing lever							
273	M9 1502 045	W501883	ナ ッ ト 15/64(28)×4	Nut (for Fig. 278) 15/64(28)							
274	M9 0601 051	W462950	歯 付 座 金 B6	Toothed lock washer							
275	MF 10A0 708	W501378	バネ 止 メ 板	Bracket							
276	ML 65B0 572	W465675	ツル 巻 キ バネ	Spring (for Fig. 275)							
277	M9 1101 030	W502032	バネ掛ケピン特殊ネジ 11/64(40)×19	Pin (for Fig. 276)							
278	M9 1506 015	W501246	段 付 平 ネ ジ 15/64(28)×16	Hinge screw							
279	MN 15A0 321	W459355	返シ縫イ板	Reverse sewing lever							
280	M9 1201 010	W501934	皿 ネ ジ 3/16(28)×10	Screw (for Fig. 279) 3/16(28)×10							
281	M9 0601 051	W462950	歯 付 座 金 B6	Toothed lock washer							
282	M9 1202 045	W500001	ナ ッ ト 3/16(28)×4	Nut (for Fig. 280) 3/16(28)							
283	ML 65B0 953	W465676	連 結 板	Reversing link							
284	MM 11A0 352	W446142	カ ラ ー	Reversing shaft collar							
285	M9 1506 001	B 509087	頭ナシ止メネジ 15/64(28)×7	Set screw (for Fig. 284) 15/64(28) × 6							
286	M9 1508 001	B 509088	頭ナシ止メネジ 15/64(28)×8	Set screw (for Fig. 287) 15/64(28) × 7							
287	ML 65B0 833	W452930	メ タ ル	Reversing shaft bushing							
288	ML 65B0 320	W464078	返シ縫イ軸	Reversing shaft							
289	M9 1503 001	B 508971	頭ナシ止メネジ 15/64(28)×4.5	Set screw (for Fig. 290) 15/64(28) × 4							
290	MN 15A0 323	W461018	返シ縫イ腕	Reverse sewing crank arm							
291	M9 1106 001	B 509266	頭ナシ止メネジ 11/64(40)×4.3	Set screw (for Fig. 290) 11/64(40) × 4							
292	MN 15A0 886	W460582	揺 動 腕	Reversing support link							
293	M9 1503 001	B 508971	頭ナシ止メネジ 15/64(28)×4.5	Set screw (for Fig. 294) 15/64(28) × 4							
294	MN 15A0 323	W461018	返シ縫イ腕	Reverse sewing crank arm							
295	M9 1202 001	W500151	頭ナシ止メネジ 3/16(28)×6	Set screw (for Fig. 294) 3/16(28) × 6.5							
296	M9 1502 045	W501883	ナ ッ ト 15/64(28)×4	Nut (for Fig. 298)							
297	M9 0601 051	W462950	歯 付 座 金 B6	Toothed lock washer							
298	M9 0513 063	W465677	偏 心 ビ ン	Eccentric pin							
299	ML 65B0 454	W464079	軸	Reversing support shaft							
300	MF 10E2 148	W462729	油 ヒ モ 2.5φ×125	Oil wick							
301	M9 0507 065	W464080	E 型 止 メ 輪 E7	Retaining ring (E type)							
302	ML 65B1 833	W452935	メ タ ル	Reversing shaft bushing							
303	M9 1508 001	B 509088	頭ナシ止メネジ 15/64(28)×8	Set screw (for Fig. 302) 15/64(28) × 7							
304	ML 65B0 320	W464078	返シ縫イ軸	Reversing shaft							
305	M9 1106 001	B 509266	頭ナシ止メネジ 11/64(40)×4.3	Set screw (for Fig. 294) 11/64(40) × 3.75							

CU-865形 返し縫い関係 REVERSE SEWING MECHANISM

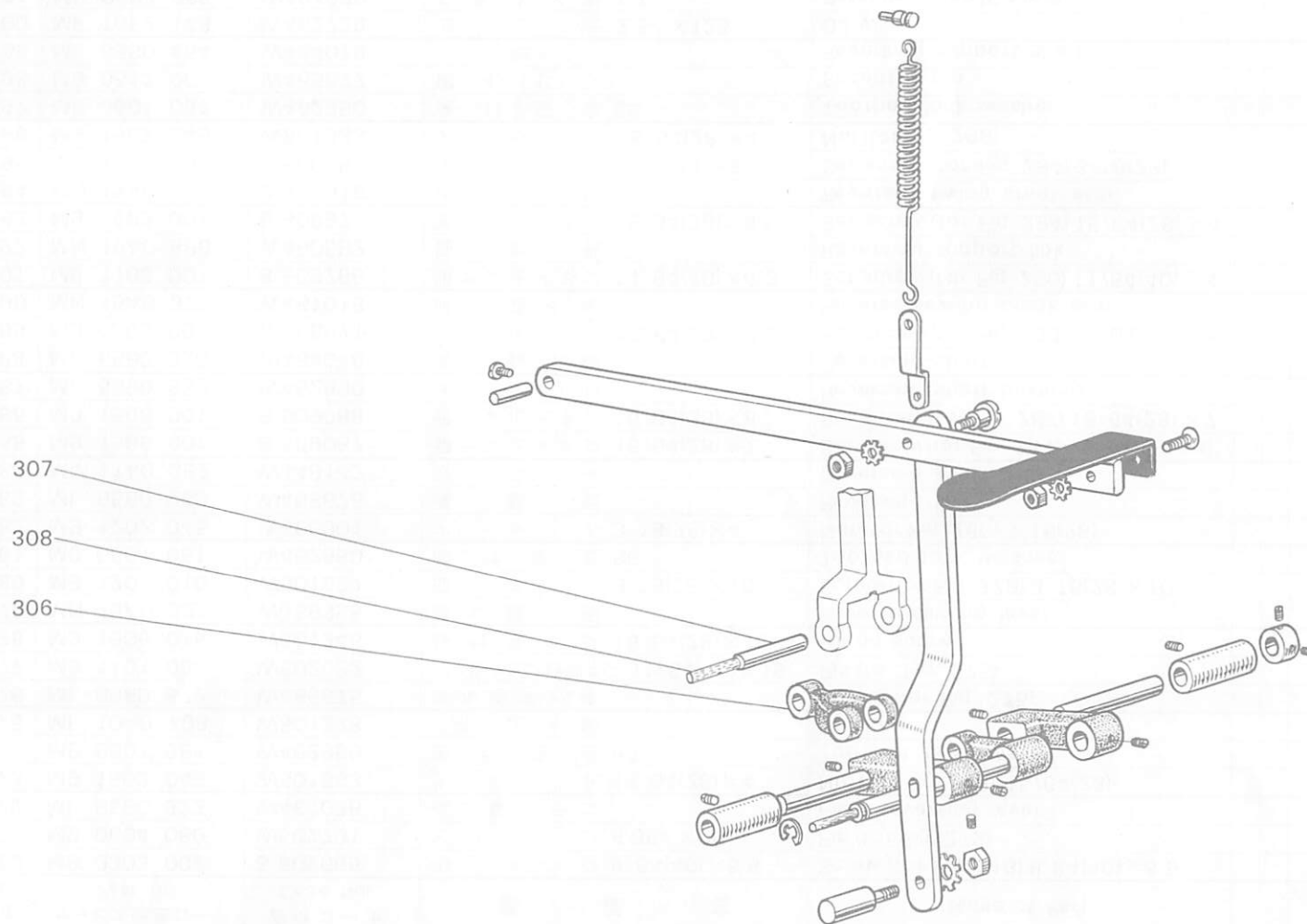

<CU-865形> 返し縫い関係 REVERSE SEWING MECHANISM

Fig. No.	サービス部品コード Part No.	資材コード Code No.	部 品 名	Name of Part	個 / 台 Amt. req								備 考 Remarks
306	MN 15A0 910	W460584	リ ン ク	Feed driving connection link									
307	M9 0703 060	W502921	ピ ン 9.94φ×29	Feed driving connection link pin									
308	MF 10E2 148	W462981	油 ヒ モ 2.5φ×60	Oil wick (for Fig. 307)									

CU-865形 送り関係 FEED ROCK SHAFT MECHANISM

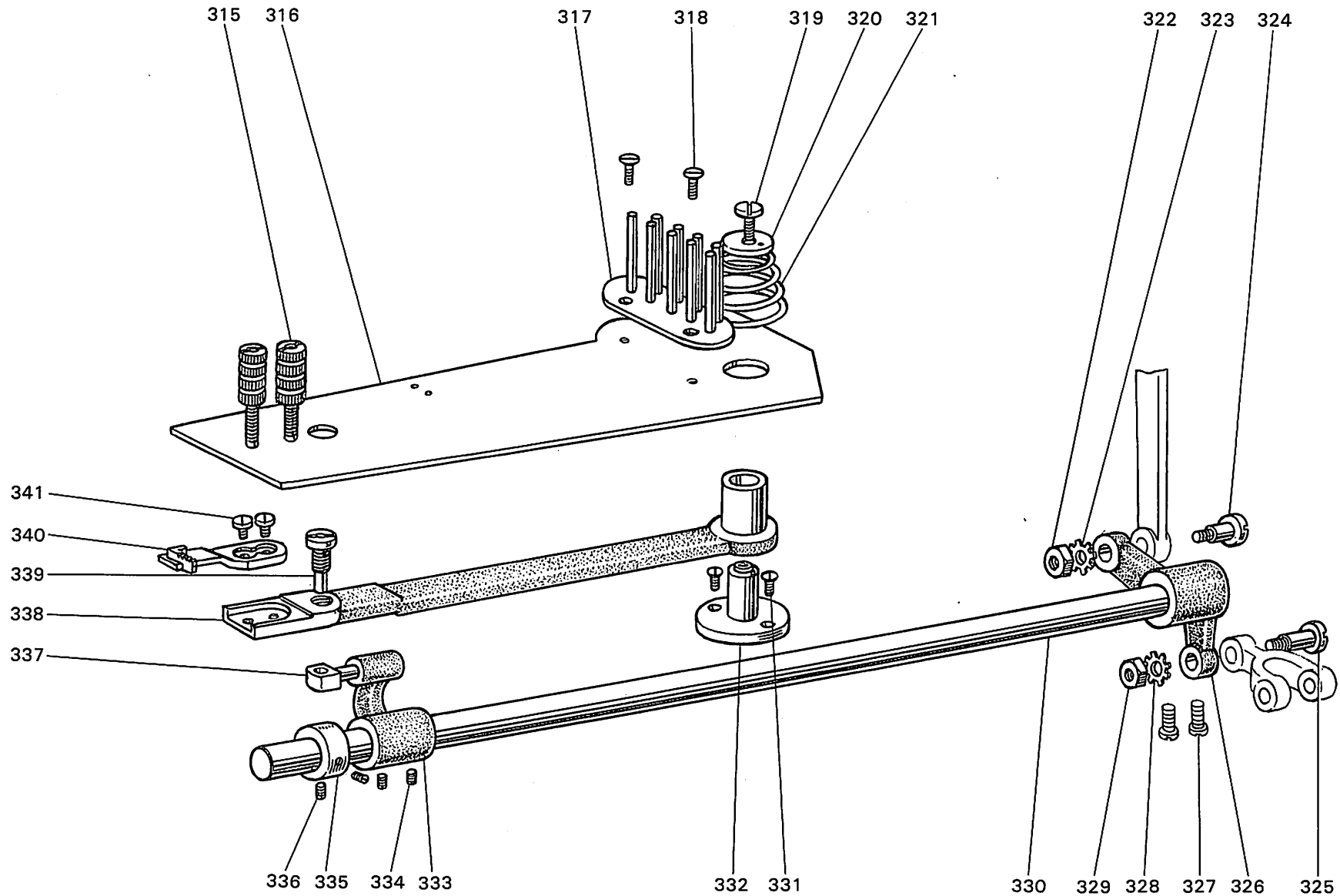

<CU-865形> 送り関係 FEED ROCK SHAFT MECHANISM

Fig. No.	サービス部品コード Part No.	資材コード Code No.	部 品 名	Name of Part	個 / 台 Amt. req					備 考 Remarks
315	M9 1101 047	W464099	調 節 ネ ジ 11/64(40)×19	Nut						
316	ML 65B0 154	W464096	送 り 案 内 板	Feed plate						
317	ML 65B0 527	W464097	台 板	Bese plate						
318	M9 0901 011	W500078	丸 皿 ネ ジ 9/64(40)×4	Screw (for Fig. 317) 9/64(40)×4.5						
319	M9 1119 002	W500491	平 ネ ジ 11/64(40)×6.8	Screw (for Fig. 320) 11/64(40)×6						
320	M9 3002 052	W464094	特 殊 座 金 6φ×20φ×2.4t	Washer						
321	ML 65B0 245	W464095	円 錐 バ ネ	Conical spring						
322	M9 1502 045	W501883	ナ ッ ツ ト 15/64(28)×4	Nut 15/64(28)						
323	M9 0601 051	W462950	齒 付 座 金 B6	Toothed lock washers						
324	M9 1508 016	W464082	段 付 丸 平 ネ ジ 15/64(28)×24	Hinge screw						
325	M9 1510 015	W464083	段 付 平 ネ ジ 15/64(28)×28	Stud screw (for Fig. 326)						
326	ML 65B0 275	W464081	送 り 腕 (右)	Feed rock shaft crank (right)						
327	M9 1502 002	W500509	平 ネ ジ 15/64(28)×12	Screw (for Fig. 326) 15/64(28)×12						
328	M9 0601 051	W462950	齒 付 座 金 B6	Toothed lock washers						
329	M9 1502 045	W501883	ナ ッ ツ ト 15/64(28)×4	Nut 15/64(28)						
330	ML 65B0 284	W464089	送 り 軸	Feed rock shaft						
331	M9 1203 003	W501957	丸 平 ネ ジ 3/16(28)×6	Screw 3/16(28)×6						
332	ML 65B0 429	W464092	送 り 揺 動 テ コ 支 エ 台	Feed bar stand						
333	ML 65B0 273	W464090	送 り 腕	Feed rock shaft crank						
334	M9 1502 001	B 509349	頭 ナ シ 止 メ ネ ジ 15/64(28)×3.5	Set screw (for Fig. 333) 15/64(28)×3						
335	ML 65B1 352	W464091	カ ラ ー	Collar (for Fig. 333)						
336	M9 1503 001	B 508971	頭 ナ シ 止 メ ネ ジ 15/64(28)×4.5	Set screw (for Fig. 335) 15/64(28)×4						
337	ML 65B0 487	W464401	ス ベ リ	Slide block						
338	ML 65B0 281	W464093	送 り 台	Feed bar						
339	M9 2001 033	W464400	ビ ン ネ ジ 5/16(28)×15	Screw pin						
340	ML 65B0 104	W464404	送 り	Feed dog						
341	M9 1115 002	W500121	平 ネ ジ 11/64(40)×4.2	Screw (for Fig. 340) 11/64(40)×4.2						

CU-865形 給油関係 LUBRICATION MECHANISM

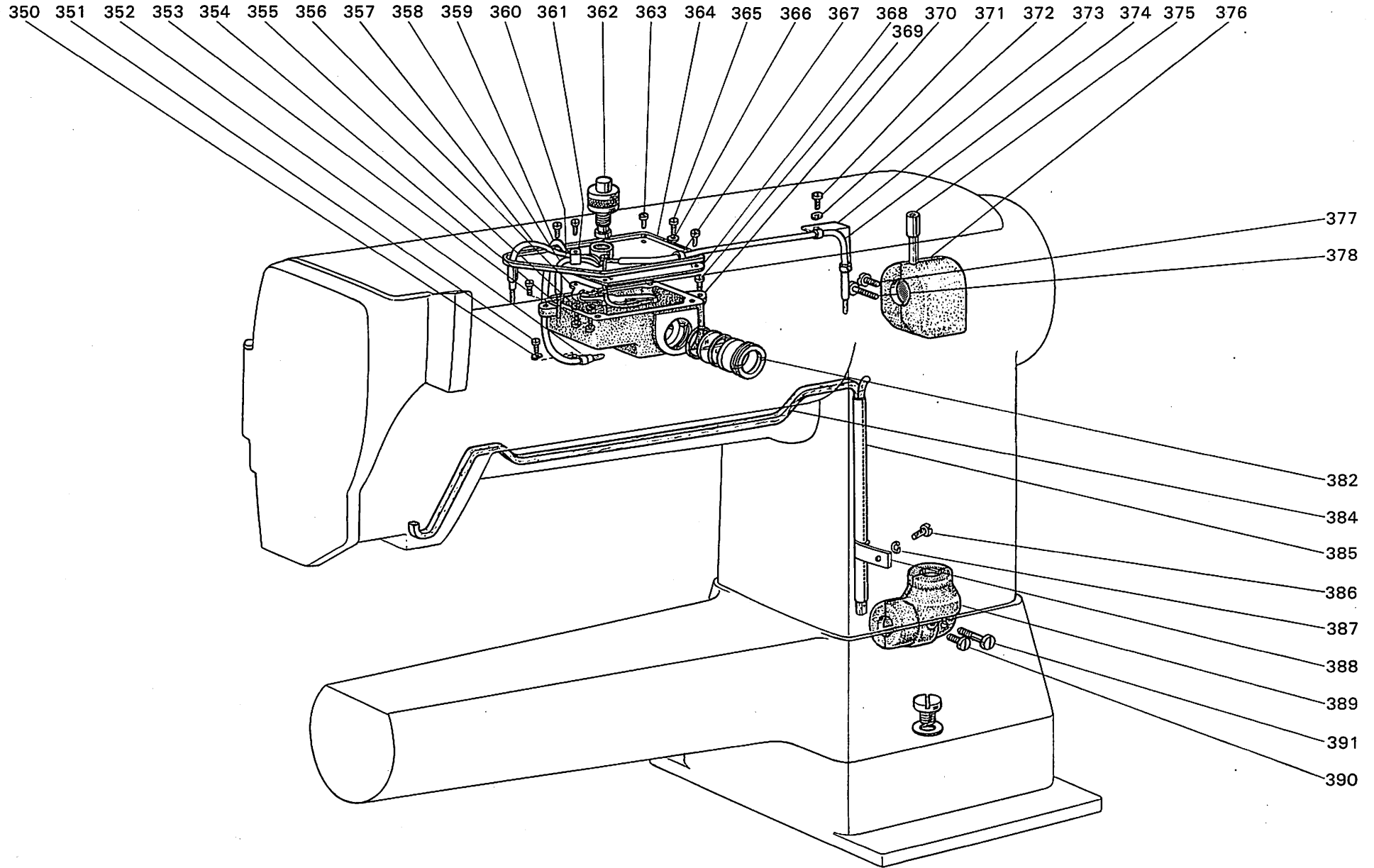

<CU-865形> 給油関係 LUBRICATION MECHANISM

Fig. No.	サービス部品コード Part No.	資材コード Code No.	部 品 名	Name of Part	個 / 台 Amt. req					備 考 Remarks
350	M9 0302 053	W462953	バネ座金 3.5	Spring washer						
351	M9 0903 002	B 509065	平ネジ 9/64(40)×6.5	Screw 9/64(40)×6.5						
352	MF 10A0 689	W444230	パイプホルダー	Oil cotton braid holder						
353	M9 0924 002	B 509068	平ネジ 9/64(40)×10	Screw 9/64(40)×10						
354	M9 0804 002	B 503897	平ネジ 1/8(44)×3.5	Screw 1/8(44)×3.5						
355	M9 0301 053	W461769	バネ座金 3	Springwasher						
356	MN 10A1 192	W446556	板バネ	Leaf spring						
357	MF 10E2 148	W462982	油ヒモ 2.5φ×330	Oil wick						
358	MN 10A5 740	W462954	フェルト	Felt						
359	MP 00B0 731	W462993	ビニールパイプ	Oil cotton braid holder pipe						
360	MF 10E2 148	W462729	油ヒモ 2.5φ×125	Oil wick						
361	MN 10A0 689	W501220	パイプホルダー	Oil cotton braid holder						
362	MN 10A0 528	W462955	ダーナー	Oil plunger danner						
363	M9 0903 002	B 509065	平ネジ 9/64(40)×6.5	Screw 9/64(40)×6.5						
364	MP 00B0 742	W326231	フタ板	Oil tank cover						
365	M9 0903 002	B 509065	平ネジ 9/64(40)×6.5	Screw 9/64(40)×6.5						
366	M9 0302 053	W462953	バネ座金 3.5	Springwasher						
367	MF 10A0 659	W444230	パイプホルダー	Oil cotton braid holder						
368	MN 10A2 691	W444116	パッキン	Gasket						
369	M9 0903 002	B 509065	平ネジ 9/64(40)×6.5	Screw 9/64(40)×6.5						
370	MN 10A0 139	W444114	油タンク	Oil tank						
371	M9 0903 002	B 509065	平ネジ 9/64(40)×6.5	Screw 9/64(940)×6.5						
372	M9 0302 053	W462953	バネ座金 3.5	Springwasher						
373	MN 25A1 689	W446499	パイプホルダー	Oil cotton braid holder						
374	MN 10A0 731	W462994	ビニールパイプ	Oil cotton braid holder pipe						
375	M9 0512 063	W464069	ピン 5φ×27	Pin						
376	MF 60E0 711	W464017	歯車箱 (上)	Gear case(up)						
377	M9 1851 002	B 504000	平ネジ 9/32(20)×16	Screw 9/32(20)×16						Fig.No.376ニ含ま
378	M9 1503 002	W462784	平ネジ 15/64(28)×5	Screw 15/64(28)×5						
382	MN 25A0 135	W472784	油窓	Oil check window						新W472784
384	MN 25A1 740	W462956	フェルト	Oil return felt						
385	MN 10A1 731	W462995	ビニールパイプ	Oil felt braid holder pipe						
386	M9 0903 002	B 509065	平ネジ 9/64(40)×6.5	Screw 9/64(40)×6.5						
387	M9 0302 053	W462953	バネ座金 3.5	Spring washer						
388	MN 10A1 689	W501202	パイプホルダー	Oil cotton braid holder						
389	MF 60E0 712	W464018	歯車箱 (下)	Gear case (under)						
390	M9 1503 002	B 504000	平ネジ 15/64(28)×5	Screw 15/64(28)×5						
391	M9 1851 002	W462784	平ネジ 9/32(20)×16	Screw 9/32(20)×16						Fig. No. 389ニ含ま

